

Chimonek

02/2022



**FERRAMENTAS ESPECIAIS
PARA CONSERTO DE VEÍCULOS**

10 001

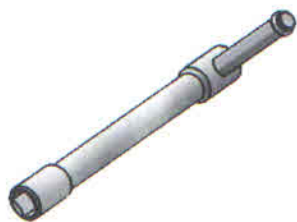

Chave T curta 140mm com soquete fixo quadrado de 8mm para acoplamento do câmbio nos veículos VW.

10 002



Chave sextavada de 22mm para a porca do amortecedor dianteiro do Gol, Golf (95 a 98), Santana, Quantun, Versailles e Royale

10 003



Chave sextavada 17mm para soltar o bujão de óleo do Fusca, Kombi e linha VW com motor AP

10 004



Chave sextavada longa de 17mm para porca do amortecedor traseiro do Santana Quantun, Versailles e Royale

10 005



Chave estriada para os parafusos da homocinética do Passat

10 006



Chave estriada longa de 10mm com soquete móvel para regular freio de mão para carros com catalizador

10 007



Chave "T"10mm longa c/ soquete móvel para soltar os parafusos do coletor de admissão VW e parafusos de fixação do cárter do VW Golf

10 008



Chave para soltar a porca do amortecedor dianteiro do Gol, Voyage, Parati e Saveiro (p/ máq. pneumática)

10 010



Chave estriada curta de 10mm para regular o freio do Gol (linha 98)

10 011



Chave soquete sextavado 32mm para a porca do cubo dianteiro do Verona, Santana, Logus, Tipo, Palio, Escort, Focus, EcoSport, Fit, Civic e da roda traseira do Palio, Marea, Uno, Tempra e Stilo

10 012



Chave estriada para os parafusos do cabeçote dos motores VW AP, Golf 1.6 e 2.0 (julho/01 em diante) Passat 1.8 e 2.0 (até 97), Corola 1.6 e 1.8 -16V (2003 em diante) MB Sprinter OM611 (01-12) e para soltar o amortecedor dianteiro do Omega

10 013



Chave sext. 10mm para os parafusos do cabeçote do motor Passat 1.5 e 1.6 Mitsubishi L 200 e Pajero 2.5/2.8

10 015

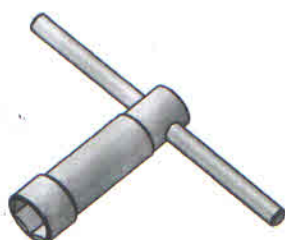

Chave sextavada de 21mm com encaixe quadrado de 1/2 para velas do motor VW

10 016



Extrator e instalador das buchas de (nylon) do quadro da suspensão tras. do Golf (98 em diante) Polo, Fox, New Beetle Audi A3

10 017



Chave estriada de 36mm p/ regular a cambagem VW refrigerado a ar

10 019



Chave sextavada de 17mm para a porca superior do amortecedor traseiro dos veículos VW Gol (95 em diante), Golf, Logus, Pointer, Ford Mondeo, Audi A3, A4 e Fiat Bravo

10 020



Chave sext. 6mm com encaixe de 1/2 para os parafusos do coletor de admissão VW AP 1.6, 1.8 e 2.0 8V comprimento (180mm)

10 021



Chave estriada para o bujão de óleo do câmbio Golf, Pólo, Fox, Passat e Audi A3 e parafusos de fixação do câmbio ao motor Bora, Golf e Audi

10 022



Chave sext. 6mm com encaixe de 1/2 com comprimento de 150mm para os parafusos do coletor de admissão do motor VW AP 1.6, 1.8, e 2.0 8V

10 023

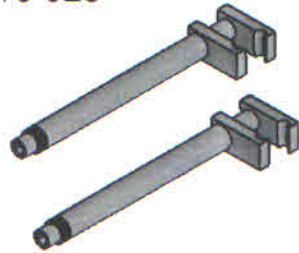

Encolhedor de molas rápido para uso com chave pneumática para molas com diam. de 100 a 206mm e espessura de até 17mm com abertura max. 250mm (não pode ser usado em molas de blindados e utilitários)

10 024



Chave sextavada de 29mm com encaixe quadrado de 1/2 para a porca do amortecedor do Passat, Gol, Santana e Parati

10 025



Chave sextavada de 16mm com soquete móvel para as velas do motor do Gol, Pálio 8 e 16 válvulas

10 026



Ferramenta para extrair e colocar os rolamentos das rodas dianteiras dos veículos VW, Fiat, GM e Ford

10 027



Chave soquete estriado de 30mm com encaixe 3/4 para o eixo diant. do Fox, CrossFox e Golf

10 028

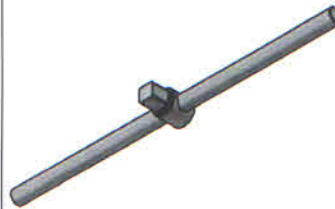

Cabo de força de 3/4"

10 029



Cabo de força de 1/2"

10 031



Ferramenta para bater a capa do rolamento VW

10 032

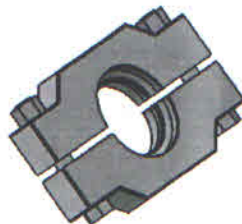

Extrator da pista do rolamento do cubo dianteiro VW, Monza e Escort

10 033

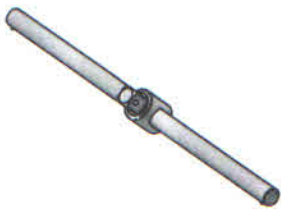

Cabo de força de 1"

10 034

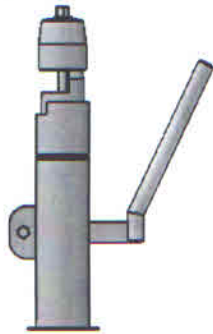

Extrator da bucha da bandeja dianteira do Santana e Monza

10 035



Jogo de ferramentas para sincronismo VW Amaro 2.0 16V diesel turbo 122 e 140 cv. e biturbo 163 e 180 cv.

10 037



Chave soquete estriado de 36mm com encaixe de 3/4 para a porca do cubo dianteiro do Polo

10 038

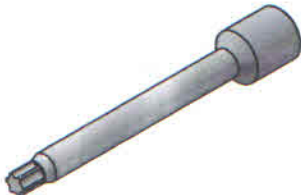

Chave para os parafusos do cabeçote do motor do Golf 1.6 e 2.0 Passat 1.8, Audi A3 1.6, 1.8 e A4 e Ford 1.0 12V 3cil. (Ka e New Fiesta)

10 039

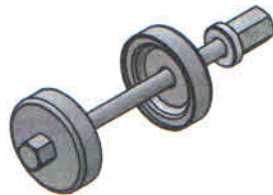

Ferramenta para colocar as buchas bipartida em aço da suspensão traseira Santana Versailles e Royale

10 045



Chave sextavada de 1" com encaixe quadrado de 1/2 para porca de encolhedores de molas tipo gancho (somente para encolhedor com porca de 1")

10 115



Chave para soltar o amortecedor do Polo, Fox, Golf, Bora, Audi e para a polia do girabrequin F 250, MWM, Sprinter, Silverado, S10 2.8 diesel

10 046



Arruela de 39mm para recuar o êmbulo da pinça de freio VW Passat 2005 em diante (usar com a ferramenta nº 12 104)

10 047



Chave para filtro de óleo do Gol 4º e 5º geração e outros com diâmetro entre 66 a 76mm

10 048

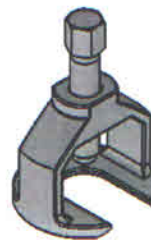

Extrator do terminal de direção do Fusca, Corsa, Celta 1.0/1.4, Escort, Palio, Marea, Brava, Uno, Tipo, Tempra e Citroën C3

10 049

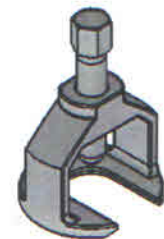

Extrator do terminal de direção do Gol, Parati e Saveiro (até 94), Meriva, Astra, Vectra, Zafira, Honda Fit e Civic

10 050

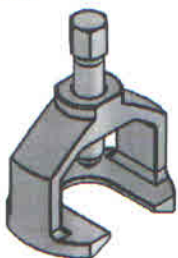

Extrator do terminal de direção do Santana, Quantun, Linha Gol, Parati e Saveiro 95 em diante, Ford Versailles, Royale, Monza, Corsa 1.0 16V e Mitsubishi L200

10 051

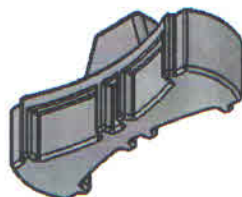

Ferramenta para sincronizar as polias das árvores de comando de válvulas do motor AT 1.0 16V (aspirado ou turbo) do Gol, Parati e Polo Classic

10 052

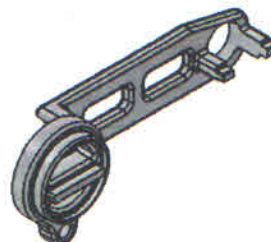

Ferramenta para sincronizar as polias das árvores de comando de válvulas dos motores VW EA211 1.0 12V MPI (3cil.) e 1.6 16V MSI.

10 053

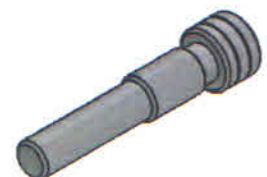

Pino para sincronizar a árvore de manivelas dos motores VW EA211 1.0 12V MPI (3cil.), 1.0 12V TSI (3cil.), 1.4 16V TSI/TFPI e Audi 1.6 16V MSI

10 054

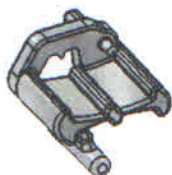

Ferramenta para sincronizar as polias ("triovais" com variador único ou duplo) das árvores de comando de válvulas dos motores VW EA211 1.0 12V MPI (3cil.) e 1.0 12V TSI (3cil.)

10 055

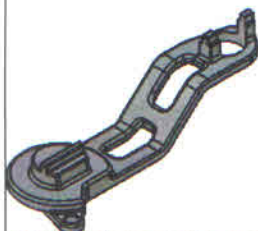

Ferramenta para sincronizar as polias das árvores de comando de válvulas dos motores VW EA211 1.0 12V TSI (3cil.) e 1.4 16V TSI/TFSI.

10 056

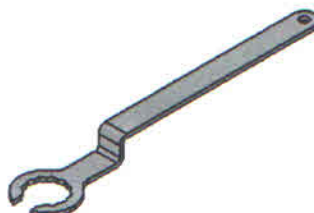

Ferramenta para imobilizar o tensionador da correia dentada dos motores VW EA211 1.0 12V MPI (3cil.), 1.0 12V TSI (3cil.), 1.4 16V TSI/TFSI e Audi 1.6 16V MSI

10 057

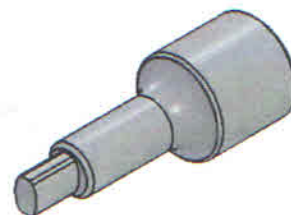

Chave para expansão da manga de eixo usada para trocar o amortecedor dianteiro do VW Bora, Golf, Polo, Audi A3, Ford Fiesta (2002 em diante) e Escort (97 em diante) e Citroën C3

10 058

Kit de ferramentas para sincronizar os motores VW/Audi EA211 1.0 12V MPI/TSI, 1.4 16V TSI/TFSI e 1.6 16V MSI

Contendo as ferramentas 10052, 10053, 10054, 10055 e 10056

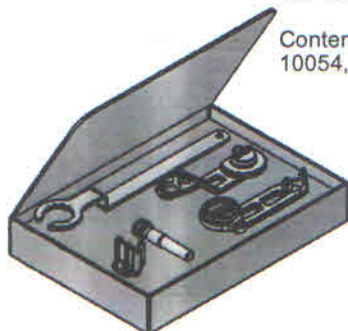

10 059



Ferramenta para instalar roda fônica na árvore de manivelas dos motores VW com ignição estática e retentor da marca Corteco/Freudenberg

11 050



Chave sextavada de 18mm para o amortecedor traseiro do Corsa e dianteiro do Tipo

11 052



Chave de garras para a porca do diferencial do Astra, Celta, Corsa, Meriva, Montana, Vectra e Zafira

11 053



Chave sextavada de 16mm com encaixe de 1/2 para as velas do motor do Chevette e Escort

11 054

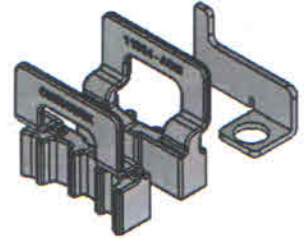

Ferramenta para sincronizar as polias com variador de fase e travar a árvore de manivelas dos motores GM 1.6/1.8 16V Ecotec do Cruze (12-16), Sonic e Tracker (13-16)

11 055

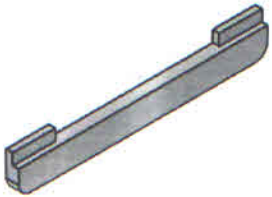

Ferramenta para sincronizar as árvores de comando de válvulas dos motores GM 1.6/1.8 16V Ecotec aplicados no Cruze, Sonic e Tracker (13 em diante)

11 056



Chave pentagonal com encaixe de 1/2 para regular a sapata de freio do Monza, Del Rey e F4000

11 057



Chave soquete sextavado de 30mm com encaixe 3/4 para o eixo dianteiro do Monza, Astra, Corsa, Celta, Vectra, Gol, Uno, Del Rey, Fiesta, Ka, e para eixo tras. Escort, Fit, Civic, Clio e Citroën C3.

11 059



Extrator do pivô da C10, D10 e D20

11 060

Kit de Ferramentas para sincronizar os motores GM 1.6/1.8 16V Ecotec do Cruze (12-16), Sonic e Tracker (13-16)

Contendo as ferramentas 11054 e 11055

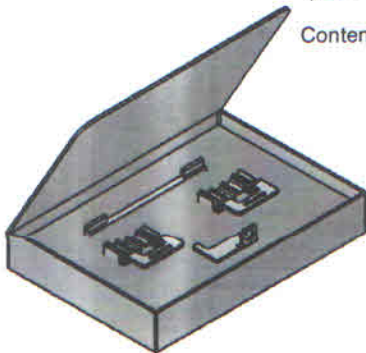

11 061



Chave sextavada de 19mm para o amortecedor dianteiro do Monza e Kadet

11 063



Chave T-55 para os parafusos do cabeçote do motor do Omega, Vectra, S10 2.2 e Escort, Fiesta e Ka (Zetec e Zetec Rocam) e Citroën, Peugeot.

11 064



Ferramenta para sincronizar às árvores de comando de válvulas do motor 2.8 turbo diesel CTDI 200 da cv S10 e TrailBlazer 13 em diante

11 065

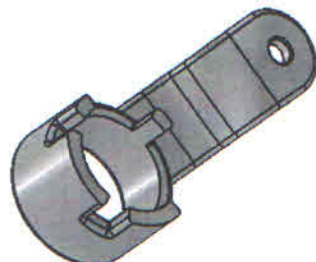

Ferramenta para sincronizar às árvores de comando de válvulas do motor 2.8 turbo diesel CTDI 180 cv da S10 e TrailBlazer 12-13

11 066



Pino de sincronismo da árvore de manivelas do motor 2.8 turbo diesel (CTDI) 180 e 200 cv S10 ano 2012 em diante

11 067

Kit de Ferramentas para sincronizar os motores GM 2.8 turbo diesel (CTDI) 180 e 200 cv S10 e trailBlazer 2012 em diante

Contendo as ferramentas 11064, 11065, 11066

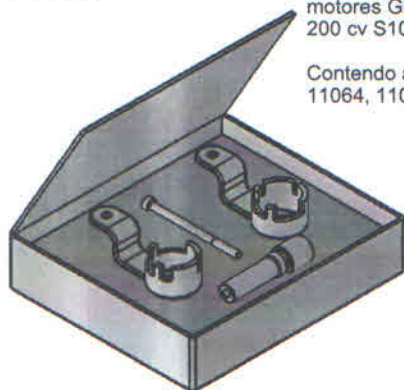

11 068



Chave para os parafusos de fixação do cabeçote do motor do Corsa

11 069

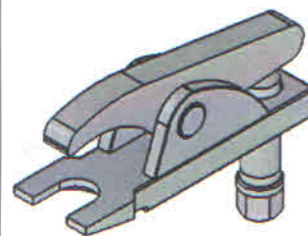

Extrator do pivô da suspensão dianteira do Monza, Kadet, Vectra, Astra, Citroën C3, Xsara Picasso, e Civic e terminal de direção do Golf (99 em diante), Polo, Fox, Bora, Audi A3, Escort, Stilo, Brava, Doblo, Clio, Corola e Land Rover.

11 070



Chave soquete estriado de 33mm com encaixe de 3/4 para a porca do pinhão da S10, F250 e Cherokee

11 074

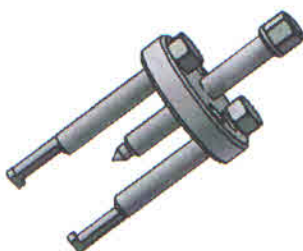

Extrator do volante de direção Chevette, Kadet e Monza

11 077

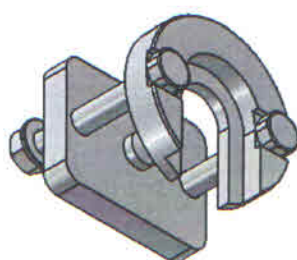

Ferramenta para sacar o braço pitmam da S10

11 078



Chave soquete sextavado de 36mm com encaixe 3/4 para a porca do eixo dianteiro S10, Blazer 4x4 (eixo dana 46) e Captiva 2.4 16V 3.0/3.6 V6.

11 079



Chave estriada de 32mm com encaixe 1/2 para a tampa do filtro de óleo do motor Ecotec 2.4 16V Captiva e Malibu

11 081



Adaptador sextavado de 19mm para quadrado de 1/2 (comprimento 22mm)

11 082

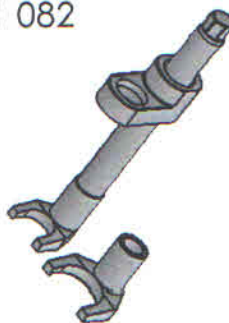

Ferramenta para comprimir as molas das válvulas no local dos motores GM 1.0, 1.4, 1.6, 1.8, 2.0, 2.2, e 2.4 8V versões Alcool, Gasolina, Flexpower, VHC, VHC-E e Econoflex

11 083



Adaptador sextavado de 27mm para quadrado de 3/4 (comprimento 35mm)

11 084

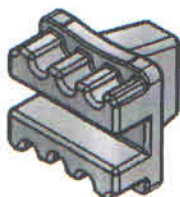

Ferramenta para sincronizar as polias das árvores de comando de válvulas do Corsa 1.0 e 1.6 16V, Meriva 1.8 16V e Fiat Stilo 1.8 16V

11 085

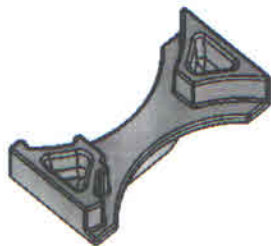

Ferramenta para sincronizar as polias das árvores de comando de válvulas do Astra, Cibra, Vectra e Zafira 2.0, 2.2 e 2.4 16V

11 087



Ferramenta para comprimir as molas das válvulas dos motores GM 1.0 e 1.4 SPE/4 do Prisma e Onix 2013 em diante (usar com a ferramenta 11082)

11 089



Ferramenta para soltar o tensionador da correia dentada linha GM (quando não for possível soltar pelo parafuso)

FORD

12 101

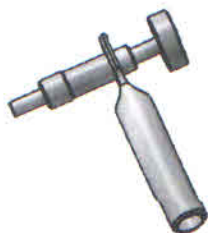

Chave 10mm para regular as válvulas dos motores Ford CHT

12 103



Chave rápida para soltar o braço da caixa de direção (diam. 36 a 41mm)

12 104

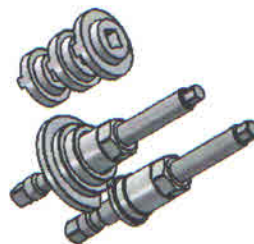

Ferramenta para recuar o êmbulo da pinça de freio a disco traseiro de automóveis, cujo freio de estacionamento tem acionamento direto nas pastilhas (com diam. 32, 38 e 40mm)

12 105



Chave soquete sextavado 13,5mm com encaixe de 1/2 para os parafusos da biela do motor CHT

12 106

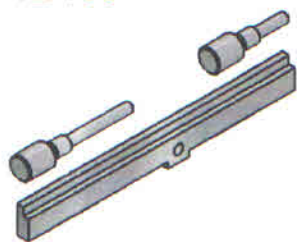

Ferramenta para sincronizar os motores Sigma 1.5 e 1.6 16V, Duratec 2.0, 2.3, 2.5 16V e Zetec 1.4, 1.8, 2.0 16V. Usar com a 12107 no motor 1.6 16V (com Variador de fase)

12 107



Ferramenta para sincronizar as polias das árvores de comando de válvulas do motor Sigma 1.6 16V do EcoSport (15-16), Focus (13-16) e New Fiesta (14-16). Para sincronizar as de comando usar (12106)

12 108

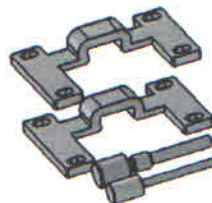

Ferramenta para sincronizar os motores Ford 1.0 12V (3cils.) TIVCT aplicados no Ka e Ka+ (Sedan) 14-16 e 1.0 12V (3cils.) EcoBoost aplicado no New Fiesta 16.

12 109

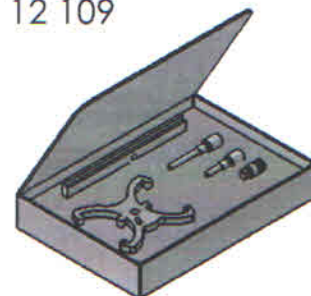

Kit de Ferramentas para sincronizar os motores Sigma 1.5 e 1.6 16V, Duratec 2.0, 2.3, 2.5 16V e Zetec 1.4, 1.8, 2.0 16V. Contendo as ferramentas 12106 e 12107

12 110



Kit de Ferramentas para sincronizar os motores Ford 1.0 12V (3cils.) TiVCT aplicados no Ka e Ka+ (Sedan) 14-16 e 1.0 12V (3cils.) EcoBoost aplicado no New Fiesta 16. Contendo as ferramentas 12 108 e 12 122

12 115



Chave para a polia do girabrequim F 250, MWM, Sprinter, Silverado, S10 2.8 diesel e para soltar o amortecedor do Polo, Fox, Golf, Bora e Audi

12 116



Suporte para relógio comparador com rosca (14mm) para verificar PMS do 1º Cilindro Palio, Brava, Marea e motores de 16V e 20V com vela central

12 117



Extrator da homocinética

12 118



Chave para soltar o braço da caixa de direção (diam.36 a 41mm)

12 121



Arruela de 30mm para recuar o êmbulo da pinça de freio Ford Focus 2008 em diante (usar com a ferramenta nº 12 104)

12 122

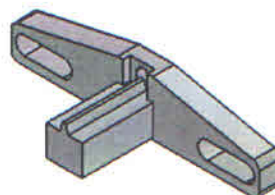

Ferramenta para travar o volante do motor do Ford Ka e New Fiesta 1.0 12V 3 cilindros

12 123



Chave para soltar o braço da caixa de direção (diam.36 a 41mm)

12 124



Chave para soltar o braço da caixa de direção (diam.42 a 48 mm)

12 125

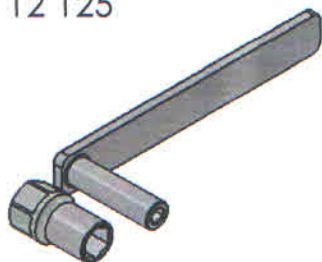

Ferramenta para trocar os amortecedores traseiros do Ford Ka (2014 a 2016), New Fiesta e Focus geração 2 e 3.

12 126

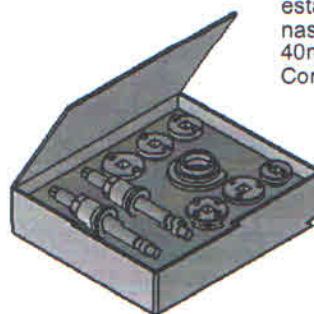

Kit de Ferramentas para recuar o êmbulo da pinça de freio a disco traseiro de automóveis, cujo freio de estacionamento tem acionamento direto nas pastilhas (com diam. 32, 38 e 40mm) e VW Passat,Ford, Focus e Corolla

13 153



Chave estriada de 17mm com encaixe de 1/2 para os parafusos do cabeçote do motor Uno, Premio 1.3 e Palio 1.5 e 1.0

13 154

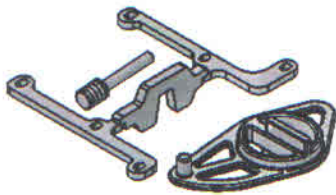

Conjunto de ferramentas para sincronizar os motores 1.0 16V (3cils.) e 1.3 8V (4cils.) Firefly dos veículos Mobi 1.0 (16) e no Uno 1.0 e 1.3 (16)

13 155



Ferramenta para travar a polia da árvore de manivelas dos motores 1.0 6V (3cils.) e 1.3 8V (4cils.) Firefly dos veículos Mobi 1.0 (16) e Uno 1.0 1.3 (16)

13 156



Conjunto de chaves para a porca dos amortecedores dianteiro da linha Uno e Palio

13 157



Ferramenta para sincronizar a árvore de manivelas dos motores FPT 2.0 16V turbo diesel MultiJet II do Fiat Toro 2016, Jeep Compass 2016 e Jeep Renegade 2015 e 2016.

13 158



Chave soquete sextavada de 36mm para a porca do cubo dianteiro do Tempra, Brava, Marea, Fit Toro e Citroën Picasso

13 159

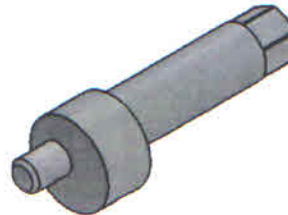

Ferramenta para regular a tensão da correia dentada dos motores FPT 2.0 16V turbo diesel MultiJet II do Fiat Toro 2016, Jeep Compass 2016 e Jeep Renegade 2015 e 2016

13 160



Chave para os parafusos do cabeçote do motor do Tempra, Tipo 2.0, Palio e Brava 1.6 16 V

13 161

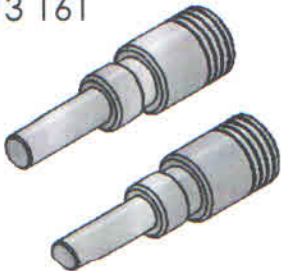

Ferramenta para sincronizar a árvore de comando de válvulas dos motores FPT 2.0 16V turbo diesel MultiJet II do Fiat Toro 2016, Jeep Compass 2016 e Jeep Renegade 2015 e 2016

13 162

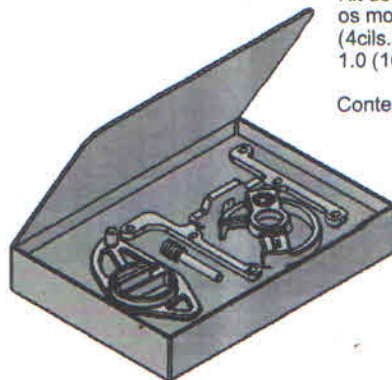

Kit de ferramentas para sincronizar os motores 1.0 16V (3cils.) e 1.3 8V (4cils.) Firefly dos veículos Mobi 1.0 (16) e no Uno 1.0 e 1.3 (16)

Contedo as ferramentas 13154 e 13155

13 163

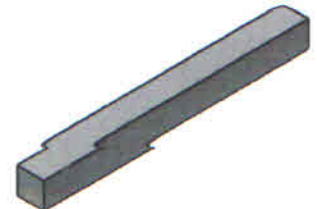

Lima brunidora 10x10x100mm

13 164

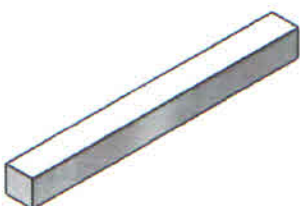

Feltro branco 10x10x100mm

13 165

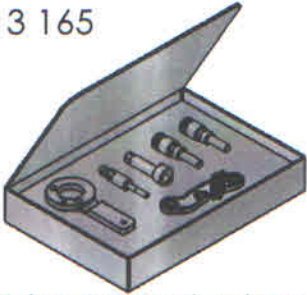

Kit de ferramentas para sincronizar os motores FPT 2.0 16V turbo diesel MultiJet II do Fiat Toro 2016, Jeep Compass 2016 e Jeep Renegade 2015 e 2016. Contendo as ferramentas 13157, 13159, 13161, 13168

13 166



Chave sextavada de 29mm com encaixe de 1/2 para o cebolão de temperatura da água do radiador

13 168

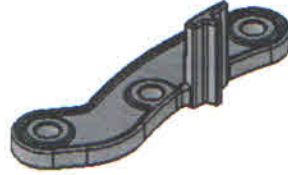

Ferramenta para travar o volante do motor FPT 2.0 16V turbo diesel MultiJet II do Fiat Toro 2016, Jeep Compass 2016 e Jeep Renegade 2015 e 2016.

13 170



Chave sextavada de 13mm com encaixe de 1/2 para as porcas das abraçadeiras do tanque de gasolina e suporte de bateria

13 171



Chave soquete sextavado de 38mm com encaixe 3/4 para a polia do motor do Fiat Uno, Elba, Fiorino 1.5 e 1.6

13 172

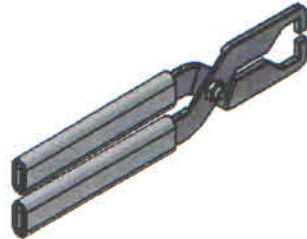

Alicate para desconectar o filtro de combustível

13 173

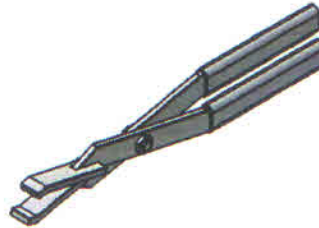

Alicate para aplicação da abraçadeira mangueira do radiador

13 182

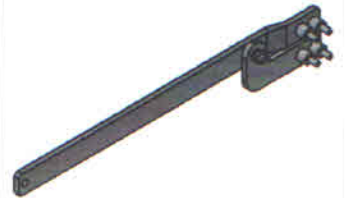

Ferramenta p/ travar as polias do comando de válvulas do Escort, Fiesta, Corsa, Vectra, Marea 16V, Fiat Fire 8 e 16V, Audi Passat V6, Peugeot e Citroën 1.0/1.4/2.0 8V, 1.0/1.8/2.0 16V e Renault 1.0/1.6/2.0 8V.

13 183



Brunidor de cilindros para motores de automóveis (abertura de 70 a 150mm)

13 186



Chave (perfil Ribe) para os parafusos do cabeçote do Marea e Alfa Romeo 164

13 188



Sacador da bucha da bandeja da suspensão dianteira do Fiat Palio

13 189



Sacador de cubo 5 furos para veículos de passeio

13 190



Chave sextavada de 13mm com encaixe de 1/2 para os parafusos do cabeçote do motor do Fire 8 válvulas

13 200



Suporte para sustentação de motores de veículos de passeio

13 201



Chave sextavada 52mm p/ o coxim do amortecedor traseiro Uno e Premio

13 202



Soquete estriado de 33 dentes para polia com catraca da marca INA de alternadores Valeo e Bosch

13 203



Sacador de cubo 4 furos para veículos de passeio

13 205



Sacador da pista do rolamento das rodas traseiras do Fiat Uno e Strada (até 2007)

13 206



Ferramenta para colocar o rolamento da coifa da homocinética do Fiat

13 208



Chave estriada de 36mm com encaixe de 1/2 para a tampa do filtro de óleo Fiat Bravo, Idea, Punto, Palio e Toro

13 211

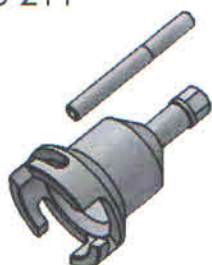

Extrator da polia do virabrequin dos motores Fiat 1.6/1.8 16V E-torq aplicados no Bravo, Doblò, Grad Siena, Idea, Linea, novo Palio, Palio, PalioWeekend, Punto, Siena e Strada

13 212



Sacador de cubo 5 furos para Fiat Ducato, Boxer, Jumper roda aro 16" e Renault Master

13 213

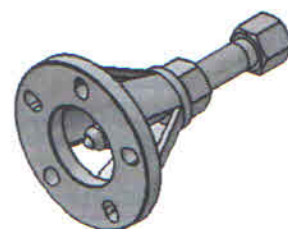

Sacador de cubo de 5 furos para Fiat Ducato, Boxer e Jumper com roda aro 15"

13 214

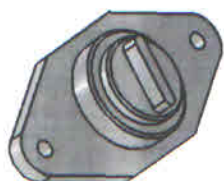

Ferramenta para sincronismo do comando de válvulas dos motores Fire 1.0, 1.3 e 1.4 8V dos veículos Idea, Mile, Palio, Palio Weekend, Punto, Siena e Strad

13 215



Ferramenta para sincronizar a árvore de manivelas dos motores 1.0 e 1.4 8V Fire Evo e 1.4 16V MultiAir (aspirado e turbo)

13 216

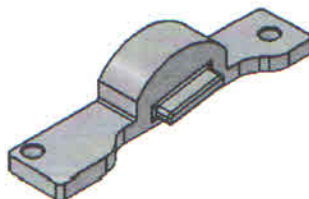

Ferramenta para sincronizar a árvore de comando de válvulas dos motores 1.0 e 1.4 8V

13 217



Ferramenta para tensionar a correia dentada dos motores Fiat Fire 1.0/1.3/1.4 8V, 1.0/1.3 16V, Fire Evo 1.0/1.4 8V e MultiAir 1.4 16V

13 218

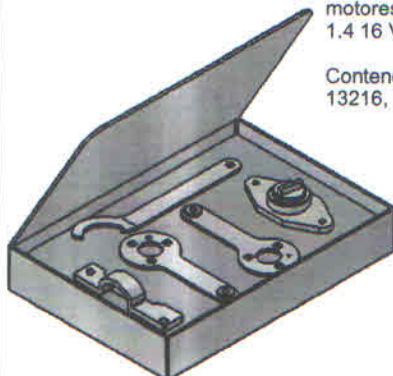

Kit de ferramentas para sincronizar os motores Fire e Fire Evo 1.0, 1.3, 1.4 8V, 1.4 16 V MultiAir (aspirado e turbo)

Contendo as ferramentas 13214, 13215, 13216, 13217 e 13219

13 219



Ferramenta para sincronizar a árvore de manivelas dos motores Fire 1.0/1.3 e 1.4 8V dos veículos Idea, Mile, Palio, Palio Weekend, Punto, Siena e Strada.

13 220



Brunidor de cilindros para motores 1.0 (abertura de 64 a 104mm)

13 221

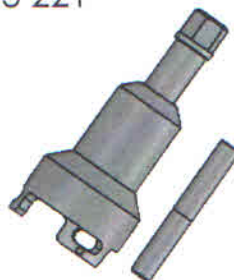

Extrator da polia da árvore de manivelas motor 1.8 16V E Torq. Evo (Fiat Cronus, Argo, Toro e Jeep Renegade)

RENAULT

14 300



Chave sextavada de 14mm para velas do motor do Clio 1.0, Peugeot 206 1.0 16V, Nissan March, Ford 1.0 12V 3 cilts, Ka, New Fiesta, Nissan 1.0 12V 3 cilts. e 1.6 / 1.8 / 2.0 16V

14 301

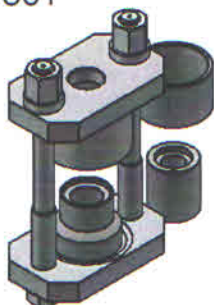

Ferramenta para trocar os pivôs da suspensão dianteira no local da Renault Master até 2012 e Sprinter

14 302



Chave com encaixe quadrado 8mm para o bujão de óleo do motor Renault

14 304



Chave para filtro de óleo do motor do Clio 1.0/1.6 16V a gasolina, Senic (todos) e Peugeot a gasolina

14 305



Arruela de 31mm e suporte para recuar êmbulo da pinça de freio Renault Master (usar com a ferramenta nº 12104)

14 306

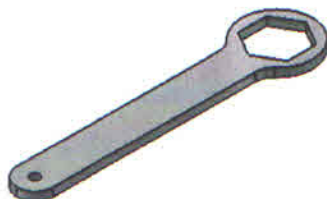

Chave sextavada de 46mm para soltar o pivô da suspensão dianteira da Renault Master 2013 até 2016

14 307

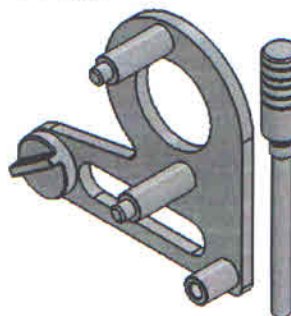

Conjunto de ferramenta para sincronizar o motor 2.3 16V turbodiesel Renault Master (13-16)

14 308

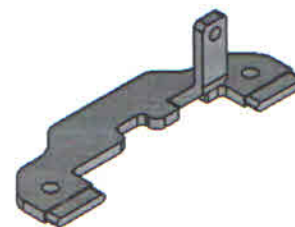

Ferramenta para sincronismo das árvores de comando de válvulas dos motores 1.6 16V(F4R) e 2.0 16 V turbo(F4RT) dos veículos Renault e Nissan Livina

14 309



Pino para sincronizar a árvore de manivelas dos motores 1.6 8V (K7M) e 1.6 16V (K4M) veículos Renault até 2016 e Nissan Livina

14 310

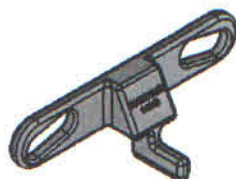

Ferramenta para travar o volante dos motores Renault 1.0 16V (D4D), 1.6 16V (K4M) e 2.0 16V(F4R) com transmissão manual, (para transmissão automática usar 12122)

14 311



Ferramenta para travar as polias do comando de válvulas do motor 1.6 16V (K4M) veículos Renault até 2016 e Nissan Livina

15 400

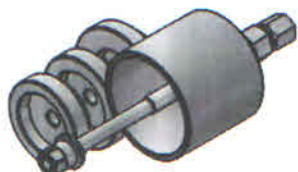

Extrator e instalador da bucha do coxín inferior do motor Peugeot e Citroën

15 401



Chave estriada de 14mm e encaixe de 1/2 para as velas dos motores Peugeot, Citroën, BMW 1.6 16V THP, aplicados no 308, 408, 508, 3008 RCZ, C4 Launge, DS3, DS4, DS5 (com borracha)

15 402

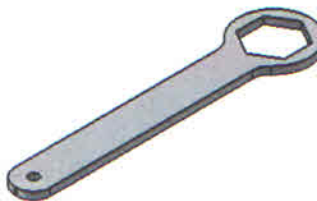

Chave sextavada de 41mm para soltar pivô da suspensão dianteira Peugeot e Citroën

15 403



Ferramenta para sincronismo dos motores PSA Peugeot e Citroën 1.0 8V (TU9M), 1.4 8V (TU3M), 1.5 8V (TU4), 1.6 8V (TU5JP), 1.6 16V TU5JP4 e EC5) e Renault 1.0 16V (D4D). No motor 1.6 16V (EC5) usar com a ferramenta 15405

15 404

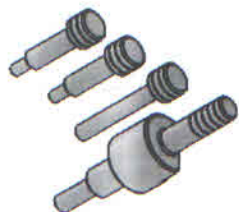

Ferramenta para sincronismo dos motores PSA Peugeot e Citroën 2.0 16V EW10J4-RFN (sem variador de fase EW10A-RFJ (com variador de fase) no motor com variador de fase (usar com a ref. 15405)

15 405

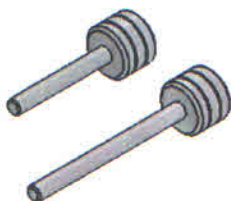

Pinos de sincronismo das polias das árvores de comando de válvulas, motor 2.0 16V (EW10A ou RFJ) com variador de fase, fabricados a partir de 2006, dos veículos Peugeot/Citrôen: 307, 308, 407, 408, C4, C4 Picasso, C5 e Grand C4 Picasso (utilizado com o conjunto 15404.)

15 406

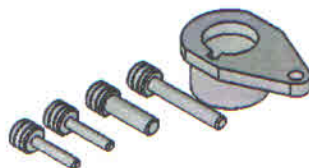

Ferramenta para sincronismo dos motores PSA Peugeot e Citroën 1.8 8V (XU7JP, XU7JB), 1.8 16V (XU10J4), 2.0 8V (XU10J2) e 2.0 16V (XU10J4-R, XU10J4-RS).

15 407

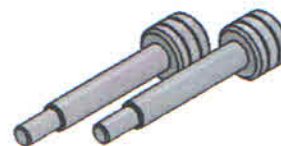

Pinos de sincronismo das árvores de comando de válvulas dos veículos Citroën: ZX e Peugeot 306 (1994 e 1995). motor XU10J4

15 408

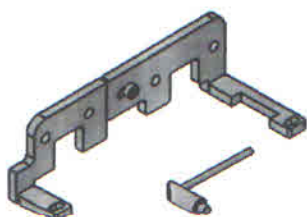

Ferramenta para sincronismo do motor PSA 1.2 12V (3 cilindros) Puretech (EB2) veículos Citroën C3 e Peugeot 208 2016 em diante

15 409

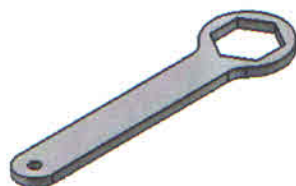

Chave sextavada de 44mm para soltar o pivô da suspensão dianteira do Furgão Peugeot Expert

15 505



Chave de 80mm com encaixe de 1/2 para filtro de óleo de veículos

MITSUBISHI

Pajero 3.0/3.5/3.8 V6
L200 Triton 3.5 24V
3000 GT 3.0 24V

KIA

Cerato 1.6/2.0 16V
Magentis 2.0 16V
Sorento 2.4 16V
SoulN 1.6 16V
Sportage 2.0
Sportage 2.7 V6

HYUNDAI

Veloster 1.6 16V
Tucson 2.7 24V
Tucson 2.0 16V
Santa Fe 2.4 16V
Santa Fe 2.7 V6
Sonata 2.4 16V
Elantra 1.6/1.8 16V
HB20/HB20S 1.6 16V

15 506



Arruela de 38mm para recuar o êmbulo da pinça de freio do Corolla (usar com a ferramenta nº 12 104)

15 508

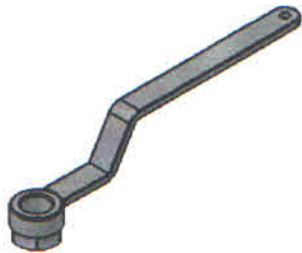

Chave sextavada de 50mm para travar a polia da árvore de manivelas do Accord, Civic e Fit

15 503



Chave de 64mm com encaixe de 1/2 para filtro de óleo (blindado e refil) veículos

NISSAN

Marh 1.6 16V
Livina 1.6 16V
Sentra 2.0
Sentra 2.0 FLEX
Tida 1.8 16V
Versa 1.6 16V

TOYOTA

Corolla 1.6 16V
Corolla 2.0 16V
Corolla 1.8 16V
HONDA
Accord 3.5 V6
Accord 2.4 16V
Accord 2.0 16V
CR-V 2.0 16V
New Civic1.8/2.0 16V
Civic 1.7 16V
City 1.5 16V
New Fit 1.4/1.5 16V
Fit 1.4/1.5 16V

15 504

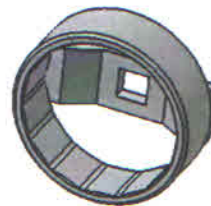

Chave de 71mm com encaixe de 1/2 para o filtro de óleo dos veículos Hyundai HB20/HB20S(1.0), Atos Prime e Kia Picanto 1.0/11

15 509



Soquete estriado de 10 lados e encaixe de 1/2 para os parafusos dos braços da suspensão traseira do Honda Civic 1.7 16V

Caminhões Scania

16 406



Chave estriada de 28mm com encaixe de 1/2 para soltar o bico injetor do motor SCANIA

16 407

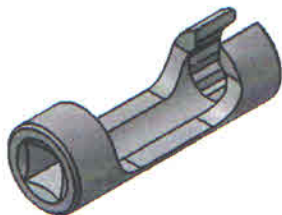

Chave estriada de 17mm com encaixe de 1/2 para soltar o cano do óleo do motor SCANIA 124G

16 408



Chave oitavada de 80mm com encaixe de 1" para a porca do cubo dianteiro 114, 124 e ônibus L-94

16 409



Chave oitavada de 100mm com encaixe quadrado de 1" para a porca do cubo traseiro sem redução do 94, 111-S, 112, 113, 114, 124, 142 e 143

17 402



Ferramenta para extrair o porta injetor do MBB 1935 e 1941

17 403



Ferramenta de ponto com rosca M10 para bomba VE usada no motor Sprinter 299 série 10

17 408



Ferramenta de ponto com rosca M8 para bomba VE usada no motor Sprinter

17 415

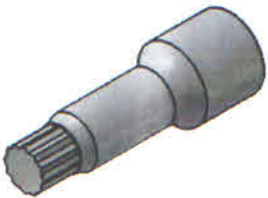

Chave para os parafusos do volante do motor Mercedes 914 C eletrônico

17 416



Chave soquete longo de 27mm para grampo de mola

17 417

Chave de garras com encaixe de 3/4 para a porca ranhurada com diam. de 95mm do cubo traseiro dos caminhões

1113, 1114, 1116 eixo HL 4/25
 1117, 1118, 1214, 1214C, 1214K eixos HL 4/25, HL 4/60
 1215 eixos HL 4/25, HL 4/60
 1215C eixos HL 4/60, HL 5/60
 1218 eixos HL 4/25, HL 4/60
 1113, 1314, 1316, 1317, 1318, 1319
 eixos HL 4/26, HL 4/27, HL 4/60, HL 5/2, HL 5/Z
 1414, 1419, 1420 eixos HL 4/26, HL 4/60, HL 5/2, HL 5/60
 1418 eixos HL 4/26, HL 4/60, HL 5/2, HL 5/60
 1513, 1514, 1516, 1517, 1518 eixos HL 5/2, HL 4/27, HL 5/Z
 1519, 1520 eixos HL 5/12, HL 5/2
 1614, 1615 eixos HL 4/27, HL 5/2
 1618 eixos HL 4/27, HL 5/2
 1620 eixos HL 5/2, HL 5/60, HL 5/61
 1621, 1625 eixo HL 5/2
 1622 eixo HL 5/60
 1714, 1718, 1721 eixos HL 4/27, HL 5/2
 1720 6x2 eixo HL 5/61
 1819, 1820-HD 4/21 G (1º eixo até 04/83) HD 4/21 DG (1º eixo) HD 4/22 D (2º eixo)
 2013, 2014, 2016, 2017- HD 4/22 D (1º eixo)
 2213, 2214, 2215, 2216, 2217-HD 4/21 D (1º eixo) HD 4/22 D (2º eixo)
 2314, 2318, 2414, 2423B 6x4 eixo HD 4/21G, HD 4/22D, HD 4/22(1º eixo)
 Ônibus
 OF/OH-1113, 1114, 1115, OF-1215, 1217 eixo HL 4/25
 1316, 1317, 1318, 1320 eixos HL 4/26, HL 5/2, (HH 4/12D Linha OH a partir de 82)
 OF/OH-1417, 1418, 1419, 1420, 1517 eixos HL 4/27, HL 5/2, HL 4/60, (HH 4/12D Linha OH)
 OH-1518 eixos HL 4/26, HH 4/12D
 OH-1520, 1521 eixo HH 4/12D
 0-355, 0-362, 0-364, 0-365 eixo OH
 0-371R, 0-371 U/UL/UP eixo HO 4/23

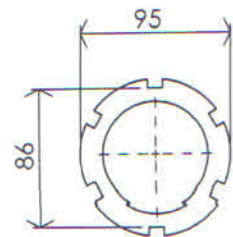
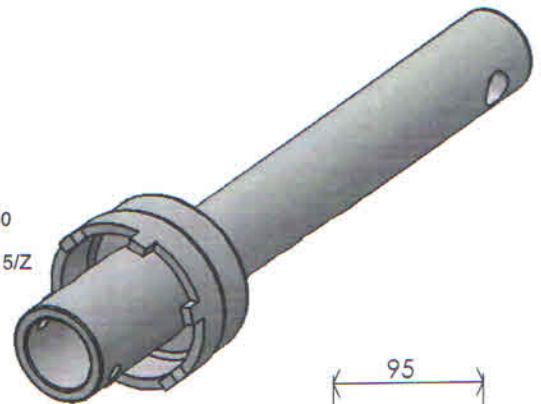

17 418



Chave de garras com encaixe de 3/4 para a porca ranhurada com diam. de 84mm do cubo traseiro dos caminhões 1113, 1114, 1116 eixo HL 4 (até ano 81)
 Ônibus OF/OH 1113, 1114, 1115 eixo HL 4 (até ano 81)

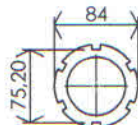

17 419



Chave de garras com encaixe de 3/4 para a porca ranhurada com diam. de 70mm do cubo traseiro dos caminhões 710, 710Plus eixo HL 2 608D/E, 610, 708E, 709, 710, 712, 712C/E, 912, 913, 914, 915, 915E eixos HL 2/5, HL 2/16, HL 2/17, HL 2/25

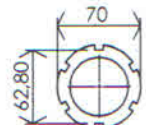

17 420

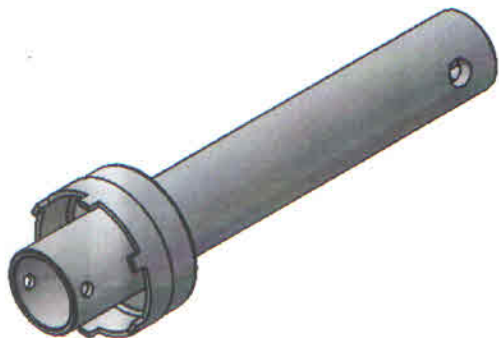

Chave de garras com encaixe de 1" para a porca ranhurada com diam. de 108mm do cubo traseiro dos caminhões

1218, 1622 eixo HL 4/61
 917, 1113, 1314, 1316, 1317, 1318, 1319 eixo HL 4/01
 1418 eixos HL 4/61, HL 4/01
 1513, 1514, 1516, 1517, 1518, 1617, 1618,
 1621, 1625 1524, 1525 eixo HL 4/01
 1630, 1632, 1633, 1634 eixo HD 4/02
 1718A, 1720 4x4 eixo HL 4/60
 2219, 2220, 2222, 2225, 2325
 eixos HD 4/02 (1º eixo) HD 4/03 (2º eixo)
 Axor 2826, Axor 2831 eixos HD 4/04, HL 4/05
 Ônibus
 OH-1420 eixos HH 4/05, HL 4/060
 OH-1421L eixo HH 4/07
 OH-1520 eixo HH 4/05
 OF/OH-1525, 1618, 1620, 1621, 1623, 1625, 1628, 1630,
 1635, 1721, 1722M eixos HL 4/060, HO 4/01, HH4/07
 O-370RS/RSD, O-371 UJULUP, O-400R/RS/RSD/RSE eixo HO 4/01

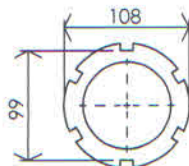

17 421

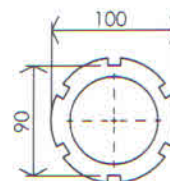
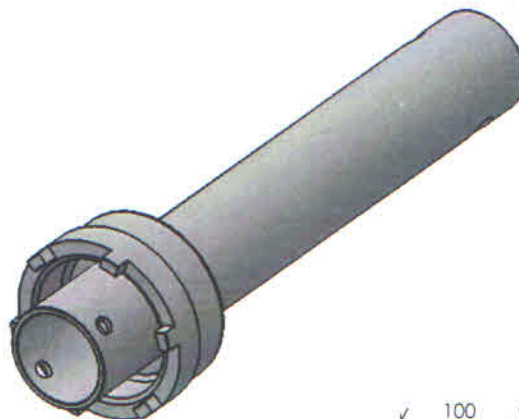

Chave de garras com encaixe de 1" para a porca ranhurada com diam. de 100mm do cubo traseiro dos caminhões

Atego 1315, Atego 1418, Atego 1518, Atego 1718,
 Atego 1725, Atego 2425, eixos HL 4/62, HL 5/61
 Atego 1725 4x4, Atego 1718, Atego 2428
 eixo HL 4/062
 1728, 1728 6x2, 1828S eixo HL 4/061
 Ônibus
 O-500, O-500M, O-500U, 500RS/RSD

17 423

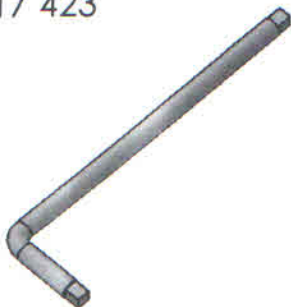

Chave com encaixe quadrado de 10mm para soltar o bujão do óleo do câmbio, Motor e Diferencial Mercedes, Ford e VW

17 424

Chave de garras com encaixe de 1" para a porca ranhurada com diam. de 122mm do cubo traseiro dos caminhões

1924, 1929, 1932, 1933, 1934, 1935, 1938S, 1938S 6x2,
 1941, 1944, 1944S, 1945 eixos HL 7/015, HL 7/020, HL 7/025
 Axor 2035, 2040, 2044, 2540, 2544, 2640, 2644 eixo HL 7/058
 2629, 2635, 2638 eixos HL 7/015, HL 7/016
 Axor 4140, 4144 e Actros 4144K eixos HD 7/057, HL 7/57
 Ônibus O-400UP/UPA eixo HO 7/01

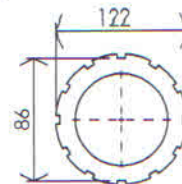
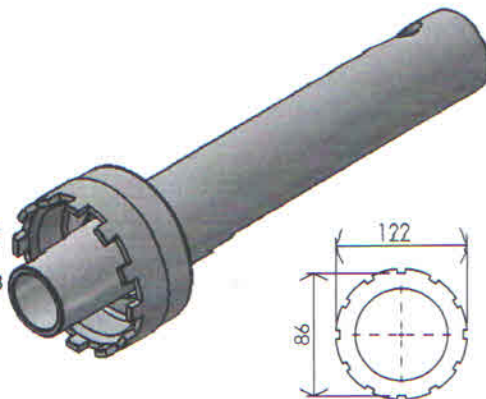

17 425

Chave de garras com encaixe de 3/4 para a porca ranhurada com diam. de 90mm dos caminhões

1313, 1314, 1316, 1317, 1318, 1319 eixo HL 4/14 (até ano 81)
 1513, 1514, 1516, 1517, 1518 eixo HL 4/8 (até ano 81)
 1819, 1820 eixo HD 4/22 (2º eixo até 04/83)
 2013, 2014, 2016, 2017 eixo HD 4/6G (1º eixo até 7/82)
 e HD 4/6 (2º eixo até 7/82)
 2213, 2214, 2215, 2216, 2217 eixo HD 4/6G (1º eixo até 04/83)
 e HD 4/6 (2º eixo até 04/83)

Ônibus
 OF/OH-1313, 1314, 1315 eixo HL 4/14 (até ano 81)
 1316, 1317, 1318, 1320, 1419, 1517 eixo HH 4/12
 (linha OH até no 81)

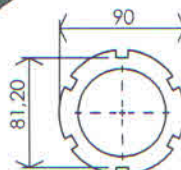
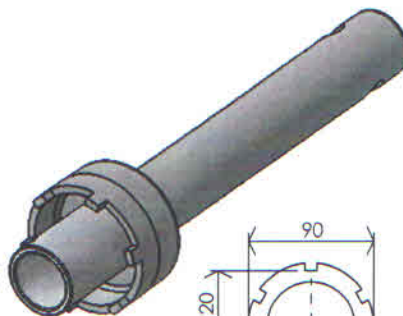

18 425



Chave sextavada de 100mm com encaixe quadrado de 1" para a porca do cubo traseiro grande (08 parafusos) Eurocargo 170E-21, 170E-22 e 230E-22

18 428



Chave sextavada de 65mm com encaixe quadrado de 3/4 para a porca do cubo traseiro Agrale, Ford e VW

18 429

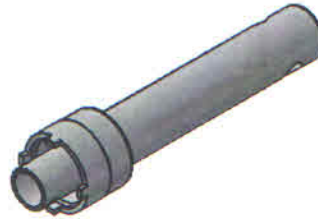

Chave de garras com encaixe de 3/4 para a porca catraca do cubo traseiro F-4000

18 430

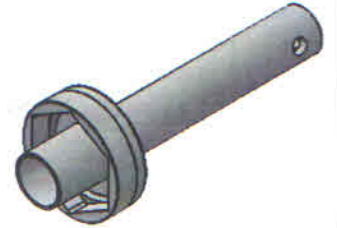

Chave sextavada de 114mm com encaixe quadrado de 1" para a porca do cubo traseiro sem redução Iveco Eurotech e Eurotrakker

18 431



Chave sextavada de 90mm com encaixe quadrado de 1" para a porca do cubo traseiro pequeno (12 parafusos) Eurocargo 170E-21, 170E-22 e 230E-22

18 432

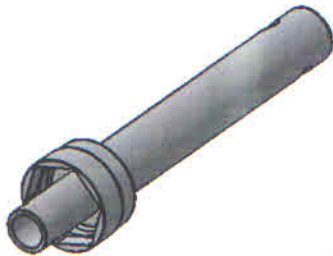

Chave sextavada de 67mm com encaixe quadrado de 3/4 para a porca do cubo traseiro do caminhões Agrale e VW/MAN com eixo Meritor MS 13.113

18 433

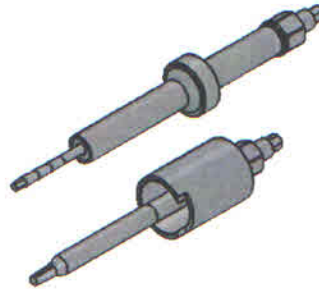

Extrator e instalador da camisa de cobre do bico injetor dos motores Volvo, D12A e D12D injeção eletrônica

19 409



Chave para remover a porca de fixação dos reguladores RQ (V) A e P

19 410



Chave para remover a porca de fixação dos reguladores EP.RS fenda de 4mm

19 413



Chave estriada com 34 dentes interno para o porta válvulas da bomba Bosch tipo P dos motores OM 447 e OM 449 Mercedes Benz

19 418

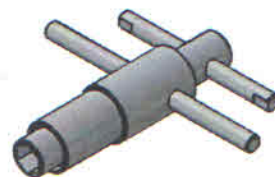

Chave para regulagem de LDA para Mercedes 352, 366, 1935 (96 em diante)

19 420



Chave com encaixe triângulo interno de 13,2 mm para os parafusos da lateral da bomba injetora V.E

19 421



Chave triângulo interno de 25,4mm com encaixe quadrado de 1/2 para o anel roscado da lateral da bomba injetora V.E

19 422



Chave oitavada de 18mm com encaixe quadrado de 1/2 para a porca do bico injetor da Ducato 2.3 Multijet

19 423



Chave bilonga de 6.5mm e 10mm para o prafuso do anel de ressalto da bomba injetora VE e CAV e da válvula reguladora da bomba de alta Hilux e Transit

19 424



Chave oitavada de 16mm para soltar a porca do bico injetor da Amarok (sistema indutivo)

19 425

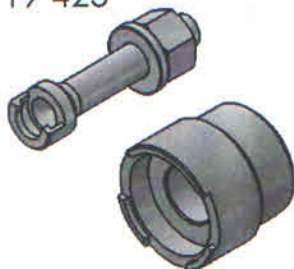

Sacador da válvula reguladora da bomba de alta (CP1,CP2 e CP3)

19 426



Chave de garras para soltar a camisa do bico injetor do Mercedes Axor

Chimonek

Rua Angelo Pessoto, 200 Jd. Boa Vista
Limeira - SP CEP: 13486-324
Telefone: 19-3453-8437 / ☎ 99299-8209
www.chimonekferramentas.com.br
ferramentas@chimonekferramentas.com.br